

Please check the examination details below before entering your candidate information

Candidate surname

Other names

**Pearson Edexcel**  
**International**  
**Advanced Level**

Centre Number

--	--	--	--	--

Candidate Number

--	--	--	--	--

**Wednesday 23 January 2019**

Morning (Time: 1 hour 20 minutes)

Paper Reference **WPH06/01**

**Physics**

**Advanced**

**Unit 6: Experimental Physics**

**You must have:**  
Ruler

Total Marks

### Instructions

- Use **black** ink or ball-point pen.
- **Fill in the boxes** at the top of this page with your name, centre number and candidate number.
- Answer **all** questions.
- Answer the questions in the spaces provided  
– *there may be more space than you need.*

### Information

- The total mark for this paper is 40.
- The marks for **each** question are shown in brackets  
– *use this as a guide as to how much time to spend on each question.*
- The list of data, formulae and relationships is printed at the end of this booklet.
- Candidates may use a scientific calculator.

### Advice

- Read each question carefully before you start to answer it.
- Try to answer every question.
- Check your answers if you have time at the end.

Turn over ►

P54563A

©2019 Pearson Education Ltd.

1/1/1/



Pearson

Answer ALL questions. Write your answers in the spaces provided.

1 (a) A student measured the diameter  $d$  of a tennis ball using vernier calipers.

(i) She closed the jaws of the calipers to check for a zero error. A zero error is a systematic error.

State what is meant by a systematic error.

(1)

(ii) Comment on whether repeat measurements are appropriate for the measurement of diameter.

(2)

(iii) The student obtained the following results.

$d/cm$	6.61	6.56	6.59	6.55
--------	------	------	------	------

The mean value of  $d$  was calculated as 6.58 cm.

Calculate the percentage uncertainty in the mean value of  $d$ .

(2)

Percentage uncertainty = .....

DO NOT WRITE IN THIS AREA

DO NOT WRITE IN THIS AREA

DO NOT WRITE IN THIS AREA



(iv) The volume  $V$  of the tennis ball is given by the equation

$$V = \frac{4}{3}\pi r^3$$

Calculate  $V$  and its uncertainty.

(3)

.....

.....

.....

.....

.....

.....

$V = \dots\dots\dots \pm \dots\dots\dots$

(b) The student bought a set of four of these tennis balls. The tennis balls were packed into a cylindrical tube of length  $l$  and internal diameter  $d$  as shown.

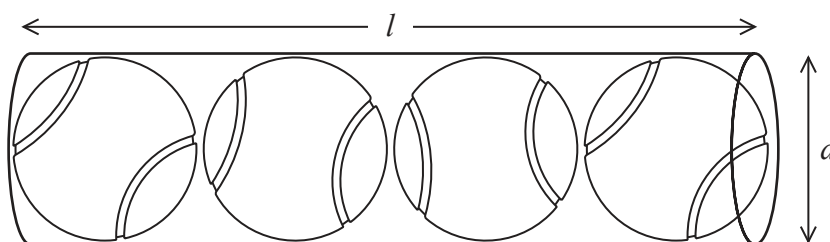

The packing fraction is defined as the ratio  $\frac{\text{total volume of tennis balls}}{\text{volume of tube}}$ .

(i) Show that the packing fraction for this arrangement is  $2/3$

(3)

.....

.....

.....

.....

.....

.....

.....

DO NOT WRITE IN THIS AREA

DO NOT WRITE IN THIS AREA

DO NOT WRITE IN THIS AREA



(ii) The volume of the tube is  $1020 \pm 30 \text{ cm}^3$ .

Determine whether the student's measurements confirm that the packing fraction is  $\frac{2}{3}$   
(4)

.....

.....

.....

.....

.....

.....

.....

.....

.....

.....

**(Total for Question 1 = 15 marks)**

DO NOT WRITE IN THIS AREA

DO NOT WRITE IN THIS AREA

DO NOT WRITE IN THIS AREA



DO NOT WRITE IN THIS AREA

DO NOT WRITE IN THIS AREA

DO NOT WRITE IN THIS AREA

**BLANK PAGE**



2 The projectile motion of a marble can be investigated using the apparatus shown.

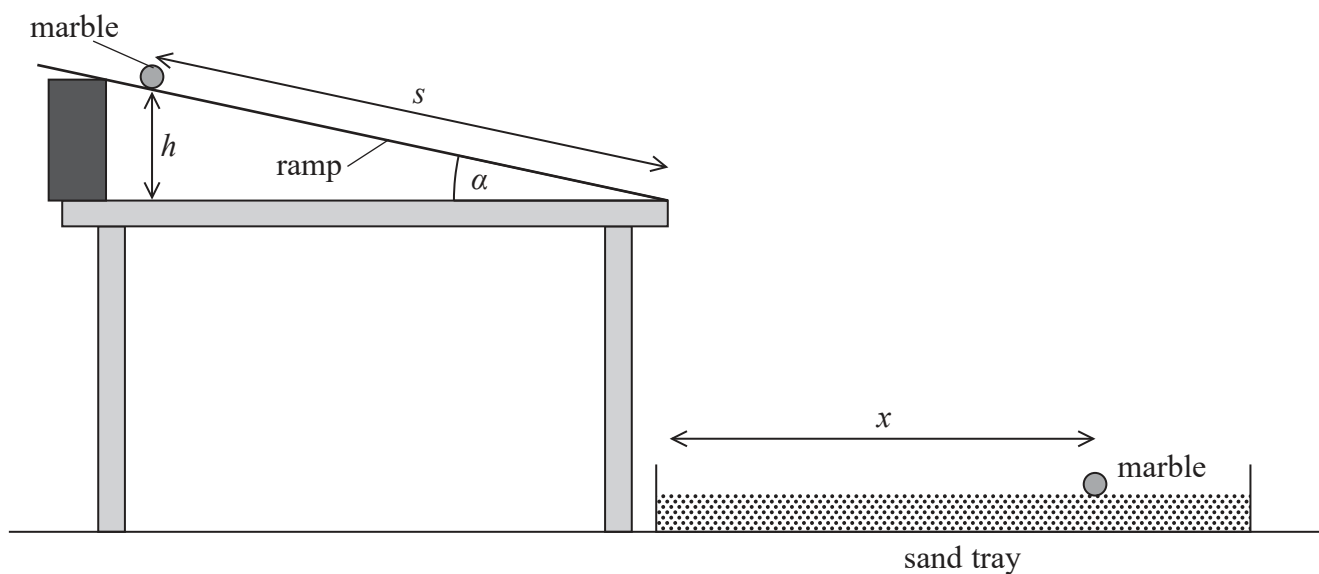

Some students investigate how the horizontal distance  $x$  the marble travels between the end of the ramp and where it lands in the sand tray is related to the angle of the ramp  $\alpha$ .

(a) The angle  $\alpha$  is adjusted so that a marble at the top of the ramp just begins to roll.

Student A measures  $\alpha$  with a protractor and records a value of  $5^\circ$ .

Student B measures the distances  $s$  and  $h$  with a metre rule and records  $s$  as 1.000 m and  $h$  as 8.7 cm. He calculates  $\alpha$  from these measurements.

Explain whether student A or student B will obtain a more accurate value for  $\alpha$ .

(4)

.....

.....

.....

.....

.....

.....

.....

.....

.....

.....



DO NOT WRITE IN THIS AREA

DO NOT WRITE IN THIS AREA

DO NOT WRITE IN THIS AREA

(b) Describe how  $x$  should be measured. You may add to the diagram if you wish.

(2)

.....

.....

.....

.....

**(Total for Question 2 = 6 marks)**



3 A student investigated the resonance of a string using the apparatus shown.

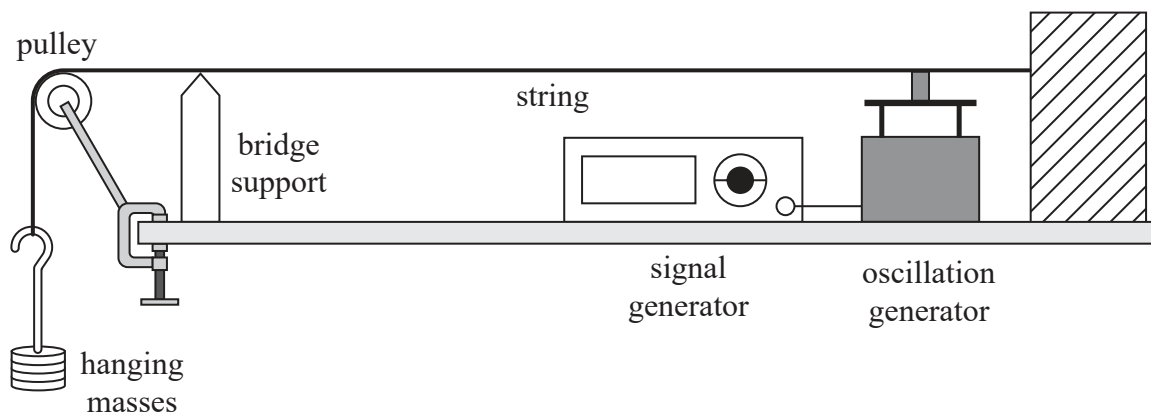

When the signal generator was switched on the string oscillated. The signal generator was adjusted until the string resonated.

(a) State what is meant by resonance.

(2)

.....

.....

.....

.....

(b) The student measured the resonant frequency  $f$  with different hanging masses.

He predicted that  $f$  would vary as

$$f = k\sqrt{m}$$

where  $m$  is the mass of the hanging masses and  $k$  is a constant.

He plotted the following graph.

DO NOT WRITE IN THIS AREA

DO NOT WRITE IN THIS AREA

DO NOT WRITE IN THIS AREA





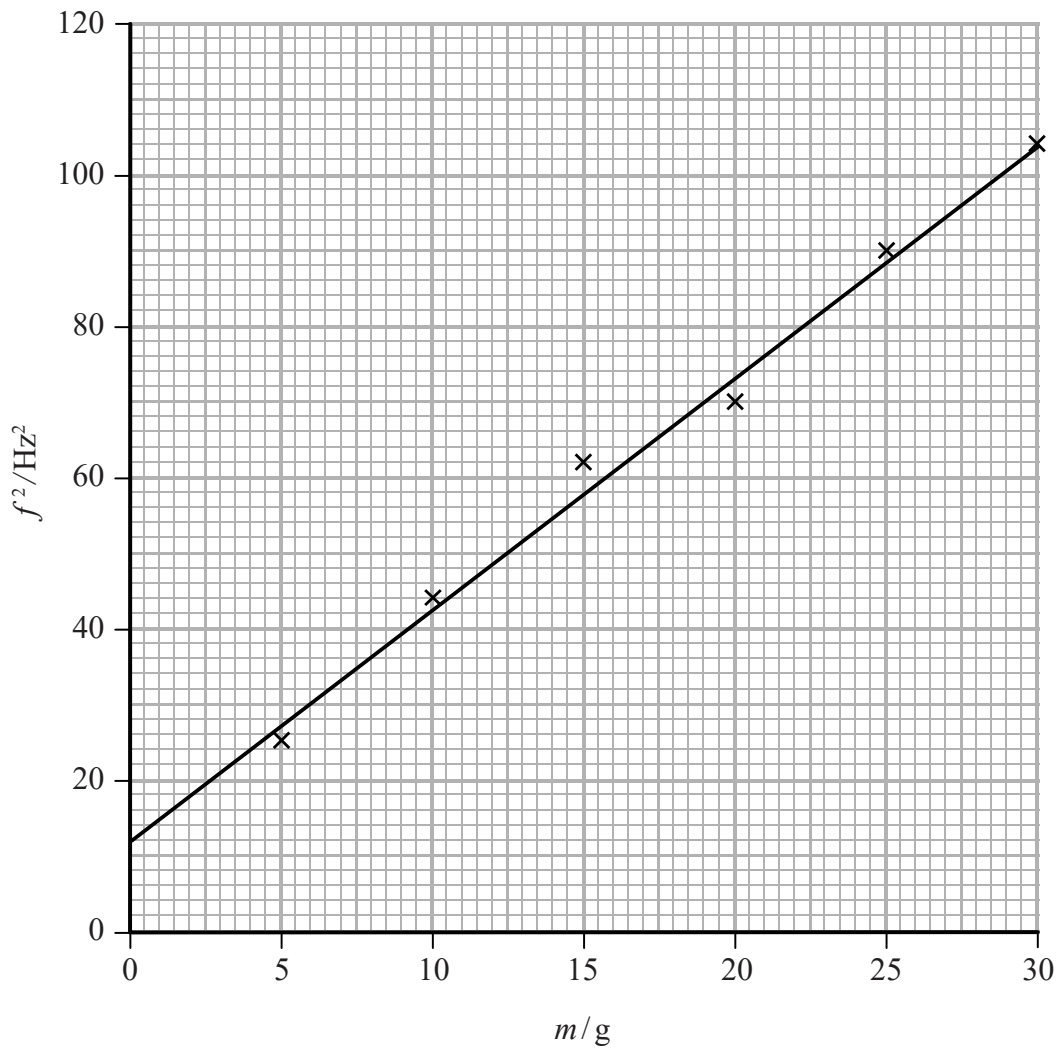

Discuss whether the graph supports the student's prediction.

(4)

.....

.....

.....

.....

.....

.....

.....

.....

.....

.....

(Total for Question 3 = 6 marks)



DO NOT WRITE IN THIS AREA

DO NOT WRITE IN THIS AREA

DO NOT WRITE IN THIS AREA

**BLANK PAGE**



- 4 A student investigated how the current  $I$  through a diode varies with the potential difference  $V$  across it. She set up the following circuit using a lamp to monitor the current.

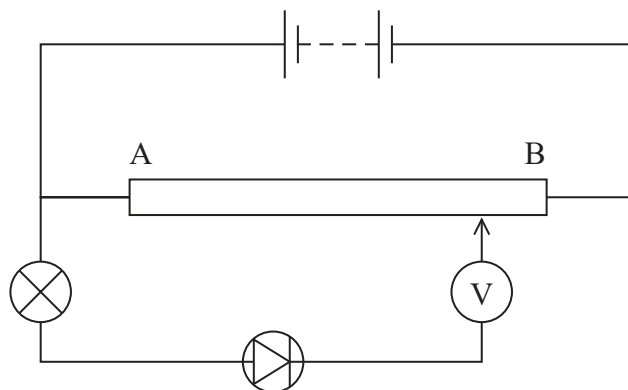

- (a) Although the components were not faulty, when the slider was moved from A to B and the voltmeter reading changed from 0 V to 3 V, the lamp did not light.

(i) Explain this observation.

(3)

(ii) State how the circuit should be modified so that the lamp will light.

(1)

- (b) In the modified circuit, the student replaced the lamp with an ammeter and a resistor.

The relationship between  $I$  and  $V$  is

$$I = ae^{bV}$$

where  $a$  and  $b$  are constants.



Explain why plotting a graph of  $\ln I$  against  $V$  will produce a straight line.

(2)

.....

.....

.....

DO NOT WRITE IN THIS AREA

DO NOT WRITE IN THIS AREA

DO NOT WRITE IN THIS AREA

(c) The student obtained the following results.

$V/V$	$I/\text{mA}$	
0.641	20	
0.662	40	
0.673	60	
0.682	80	
0.690	100	
0.695	120	

(i) Plot a graph of  $\ln I$  against  $V$  on the grid provided. Use the additional column to record your processed data.

(5)

(ii) Determine a value for  $b$ .

(2)

.....

.....

.....

$b =$  .....



DO NOT WRITE IN THIS AREA

DO NOT WRITE IN THIS AREA

DO NOT WRITE IN THIS AREA

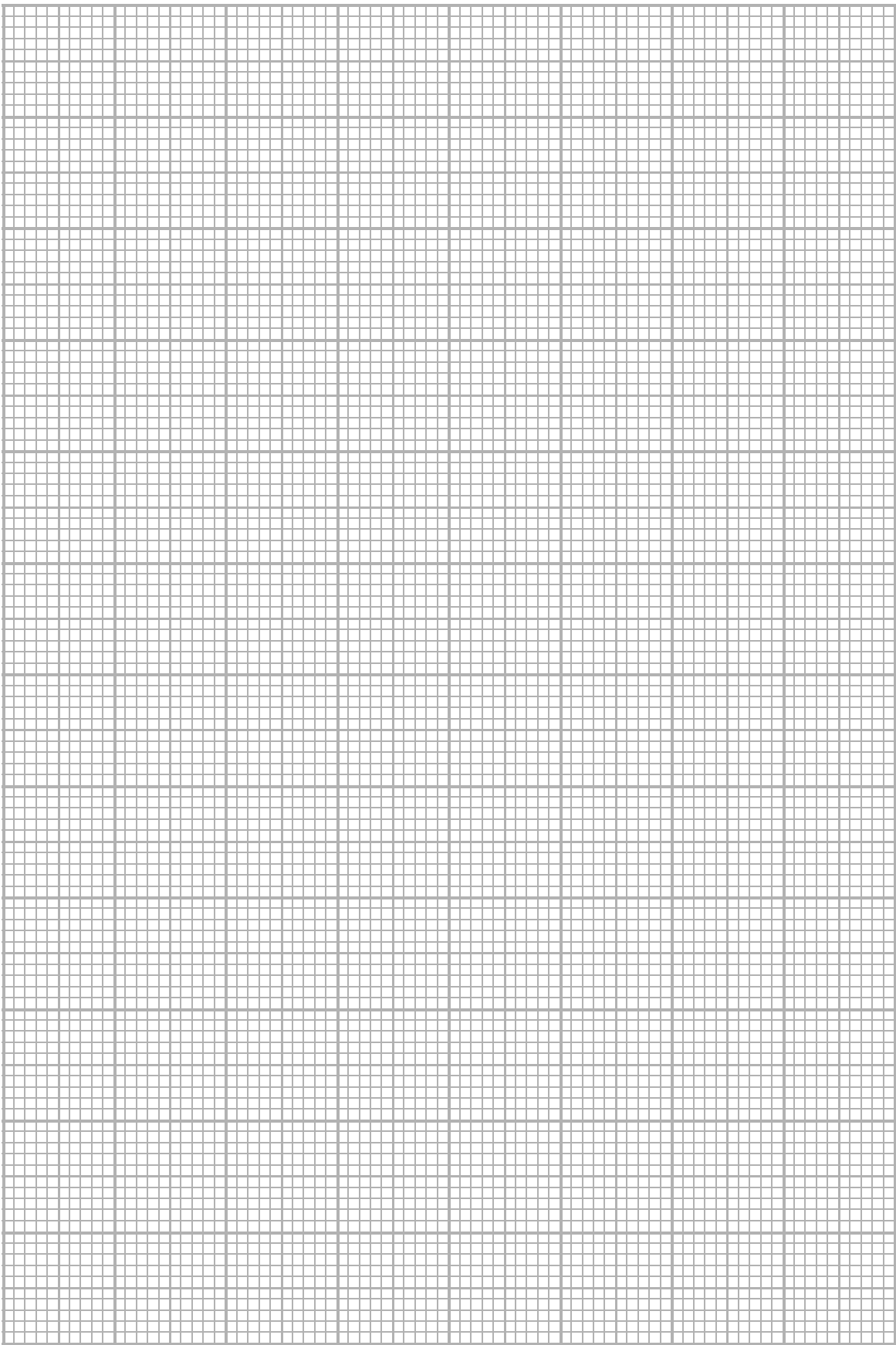

(Total for Question 4 = 13 marks)

**TOTAL FOR PAPER = 40 MARKS**



DO NOT WRITE IN THIS AREA

DO NOT WRITE IN THIS AREA

DO NOT WRITE IN THIS AREA

**BLANK PAGE**



DO NOT WRITE IN THIS AREA

DO NOT WRITE IN THIS AREA

DO NOT WRITE IN THIS AREA

**BLANK PAGE**



DO NOT WRITE IN THIS AREA

DO NOT WRITE IN THIS AREA

DO NOT WRITE IN THIS AREA

**BLANK PAGE**





### List of data, formulae and relationships

Acceleration of free fall	$g = 9.81 \text{ m s}^{-2}$	(close to Earth's surface)
Boltzmann constant	$k = 1.38 \times 10^{-23} \text{ J K}^{-1}$	
Coulomb's law constant	$k = 1/4\pi\epsilon_0$ $= 8.99 \times 10^9 \text{ N m}^2 \text{ C}^{-2}$	
Electron charge	$e = -1.60 \times 10^{-19} \text{ C}$	
Electron mass	$m_e = 9.11 \times 10^{-31} \text{ kg}$	
Electronvolt	$1 \text{ eV} = 1.60 \times 10^{-19} \text{ J}$	
Gravitational constant	$G = 6.67 \times 10^{-11} \text{ N m}^2 \text{ kg}^{-2}$	
Gravitational field strength	$g = 9.81 \text{ N kg}^{-1}$	(close to Earth's surface)
Permittivity of free space	$\epsilon_0 = 8.85 \times 10^{-12} \text{ F m}^{-1}$	
Planck constant	$h = 6.63 \times 10^{-34} \text{ J s}$	
Proton mass	$m_p = 1.67 \times 10^{-27} \text{ kg}$	
Speed of light in a vacuum	$c = 3.00 \times 10^8 \text{ m s}^{-1}$	
Stefan-Boltzmann constant	$\sigma = 5.67 \times 10^{-8} \text{ W m}^{-2} \text{ K}^{-4}$	
Unified atomic mass unit	$u = 1.66 \times 10^{-27} \text{ kg}$	

#### Unit 1

##### Mechanics

Kinematic equations of motion	$v = u + at$ $s = ut + \frac{1}{2}at^2$ $v^2 = u^2 + 2as$
Forces	$\Sigma F = ma$ $g = F/m$ $W = mg$
Work and energy	$\Delta W = F\Delta s$ $E_k = \frac{1}{2}mv^2$ $\Delta E_{\text{grav}} = mg\Delta h$

##### Materials

Stokes' law	$F = 6\pi\eta rv$
Hooke's law	$F = k\Delta x$
Density	$\rho = m/V$
Pressure	$p = F/A$
Young modulus	$E = \sigma/\epsilon$ where Stress $\sigma = F/A$ Strain $\epsilon = \Delta x/x$
Elastic strain energy	$E_{\text{el}} = \frac{1}{2}F\Delta x$



## Unit 2

### Waves

Wave speed

$$v = f\lambda$$

Refractive index

$${}_1\mu_2 = \sin i / \sin r = v_1 / v_2$$

### Electricity

Potential difference

$$V = W/Q$$

Resistance

$$R = V/I$$

Electrical power, energy and efficiency

$$P = VI$$

$$P = I^2R$$

$$P = V^2/R$$

$$W = VI t$$

$$\% \text{ efficiency} = \frac{\text{useful energy output}}{\text{total energy input}} \times 100$$

$$\% \text{ efficiency} = \frac{\text{useful power output}}{\text{total power input}} \times 100$$

Resistivity

$$R = \rho l/A$$

Current

$$I = \Delta Q / \Delta t$$

$$I = nqvA$$

Resistors in series

$$R = R_1 + R_2 + R_3$$

Resistors in parallel

$$\frac{1}{R} = \frac{1}{R_1} + \frac{1}{R_2} + \frac{1}{R_3}$$

### Quantum physics

Photon model

$$E = hf$$

Einstein's photoelectric equation

$$hf = \phi + \frac{1}{2}mv_{\max}^2$$

DO NOT WRITE IN THIS AREA

DO NOT WRITE IN THIS AREA

DO NOT WRITE IN THIS AREA



DO NOT WRITE IN THIS AREA

DO NOT WRITE IN THIS AREA

DO NOT WRITE IN THIS AREA

### Unit 4

#### Mechanics

Momentum	$p = mv$
Kinetic energy of a non-relativistic particle	$E_k = p^2/2m$
Motion in a circle	$v = \omega r$ $T = 2\pi/\omega$ $F = ma = mv^2/r$ $a = v^2/r$ $a = r\omega^2$

#### Fields

Coulomb's law	$F = kQ_1Q_2/r^2$ where $k = 1/4\pi\epsilon_0$
Electric field	$E = F/Q$ $E = kQ/r^2$ $E = V/d$
Capacitance	$C = Q/V$
Energy stored in capacitor	$W = \frac{1}{2}QV$
Capacitor discharge	$Q = Q_0 e^{-t/RC}$
In a magnetic field	$F = BIl \sin \theta$ $F = Bqv \sin \theta$ $r = p/BQ$
Faraday's and Lenz's laws	$\epsilon = -d(N\phi)/dt$

#### Particle physics

Mass-energy	$\Delta E = c^2 \Delta m$
de Broglie wavelength	$\lambda = h/p$



**Unit 5***Energy and matter*

Heating  $\Delta E = mc\Delta\theta$

Molecular kinetic theory  $\frac{1}{2}m\langle c^2 \rangle = \frac{3}{2}kT$

Ideal gas equation  $pV = NkT$

*Nuclear Physics*

Radioactive decay  $dN/dt = -\lambda N$

$$\lambda = \ln 2/t_{1/2}$$

$$N = N_0 e^{-\lambda t}$$

*Mechanics*

Simple harmonic motion

$$a = -\omega^2 x$$

$$a = -A\omega^2 \cos \omega t$$

$$v = -A\omega \sin \omega t$$

$$x = A \cos \omega t$$

$$T = 1/f = 2\pi/\omega$$

Gravitational force  $F = Gm_1 m_2 / r^2$

*Observing the universe*

Radiant energy flux  $F = L/4\pi d^2$

Stefan-Boltzmann law

$$L = \sigma T^4 A$$

$$L = 4\pi r^2 \sigma T^4$$

Wien's law  $\lambda_{\max} T = 2.898 \times 10^{-3} \text{ m K}$

Redshift of electromagnetic radiation  $z = \Delta\lambda/\lambda \approx \Delta f/f \approx v/c$

Cosmological expansion  $v = H_0 d$

